



Air-to-Water Heat Pumps with Integrated Hydronic Module

PRO-DIALOG PLUS

AQUASNAP



Carrier is participating in the Eurovent Certification Programme. Products are as listed in the Eurovent Directory of Certified Products.



Quality Management System Approval



30RH 040-240 "B"

Nominal cooling capacity 38-210 kW

Nominal heating capacity 38-229 kW

The 30RH Aquasnap heat pumps feature the latest technological innovations: ozone-friendly refrigerant HFC-407C, scroll compressors, low-noise fans made of a composite material and microprocessor control. The refrigerant circuit with its patented receiver/heat exchanger, and the auto-adaptive Pro-Dialog control system guarantee reliable and economical operation in all climates from -10°C to 45°C. Aquasnap includes a complete hydronic module as standard, simplifying the installation to straightforward operations like connection of the power supply and the water supply and return piping.

Features

- Integrated hydronic module for fast installation, incorporating all hydronic components: removable screen filter, water pump with high available pressure, expansion tank, water flow switch, safety valve, pressure gauges, and purge valve. A throttle valve allows adjustment of the water flow in accordance with the characteristics of the installation. All components are protected against frost down to -20°C.
- Low-volume water loop: the auto-adaptive algorithm controls the water temperature and eliminates any risk of excessive compressor cycling. In the majority of comfort air conditioning applications a buffer tank is unnecessary. The low water volume reduces the energy consumption during changeover from heating to cooling during in-between seasons.
- Ecological refrigerant HFC-407C: no effect on the ozone layer, replaces R-22 in air conditioning applications with small and medium capacities. Extensively tested by Carrier for several years, it offers the same performance and reliability guarantees as R-22.
- The receiver/heat exchanger (Carrier patent) enhances reliability and performance of the 30RH heat pump. In the heating mode the refrigerant is condensed in the receiver at the plate heat exchanger outlet. This device compensates for large differences in volume between the coil and the water heat exchanger (plate heat exchanger). It ensures an ideal refrigerant charge in heating and cooling mode and perfect control of subcooling or superheating. Compressor life is increased (no risk of refrigerant migration into the compressor), and the use of the heat exchangers is maximised.
- The revolutionary, low-noise, two-speed Flying Bird II fan is made of composite recyclable material and employs a multi-blade design and a rotating shroud, as used in the aeronautical industry. It is exceptionally quiet, and does not generate the low-frequency noise, irritating to the human ear. At part load or low outdoor temperatures the fan automatically switches to the low speed. To reduce the operating noise even further, the fan is not fixed to the top unit panel, but supported by an extremely rigid tower chassis.

- Defrost is optimised by the auto-adaptive algorithm. This and the new coil design reduce the defrost cycle duration by an average of 50%. For increased safety an electric heater prevents accumulation of ice on the air heat exchanger base.
- Quiet, vibration-free scroll compressors, durable and maintenance-free. The use of several compressors per circuit (from size 30RH 050) reduces the start-up current and the power consumption at part load.
- The refrigerant circuit is completely leak-proof for life. All pipes and refrigeration components are welded. Pressure sensors, mounted directly on the pipes, take the place of the pressure switches and their capillary tubes, a source of leaks in the past.
- From size 30RH 090 upwards, two independent refrigerant circuits ensure partial cooling/heating capacity in all circumstances.
- Electrical connections are simplified, and the standard Aquasnap equipment includes a main disconnect switch, and a single entry point of the three-phase without neutral power supply to the whole unit.
- Large removable panels and the hinged door of the control box ensure perfect accessibility and permit easy access to all components. Furthermore an opening allows adjustments to be made without interrupting the operation of the unit. For the most important maintenance operations the unit top cover is easily removed, and total access from above is possible, with the fan remaining in place.
- The electric resistance heater control module (accessory) permits control of up to four stages of electric heat for supplementary heating at low outdoor temperatures.
- The evaporator is a welded, stainless steel plate heat exchanger, maximising the thermodynamic properties of HFC-407C and offering considerably increased performances as well as low water-side pressure drops. From size 30RA 090 upwards the units are equipped with a twin-circuit interlaced heat exchanger for safe operation at part load. When the unit is shut down, the heat exchanger is protected against freeze-up by a trace heater.

PRO-DIALOG Plus control

PRO-DIALOG Plus is an advanced numeric control system that combines complex intelligence with great operating simplicity. PRO-DIALOG Plus constantly monitors all machine parameters, optimising the operation of compressors, fans, cycle reversing valve and water pump.

A powerful control system

- The Pro-Dialog Plus control is auto-adaptive and guarantees total protection of the compressors. The system permanently checks the operating parameters and responds to avoid excessive cycling and maintain the ideal operating range for the compressor (temperatures and pressures out of range etc.). By taking corrective action before the fault occurs, the auto-adaptive control frequently prevents a shutdown of the heat pump due to a fault condition.
- To optimise power consumption, PRO-DIALOG Plus automatically resets the chilled water temperature set-point in accordance with the outdoor air temperature or the return water temperature or uses a second set-point (example occupied/unoccupied) and ensures automatic heating/cooling changeover.
- The system also controls the start-up of a boiler relay or manages a supplementary electric heater (accessory).

Clear and easy-to-use control system

- The operator interface is clear and user-friendly: LEDs and two numeric displays ensure immediate verification of all unit operating data.
- Buttons conveniently positioned on a synoptic heat pump diagram offer immediate display of the operating parameters: temperatures, pressures, set point, run times etc.
- 10 menus offer direct access to all machine controls, including a history of possible faults, for rapid and complete heat pump fault diagnosis.

Extended communications capabilities

- PRO-DIALOG Plus allows remote control. Volt-free contacts regulate: start/stop, cooling/heating mode selection, power demand limit or selection of the second set point. The system permits remote signalling of any possible anomaly for each refrigerant circuit.
- The internal clock permits programming of:
 - Heat pump start/stop
 - operation at the second set-point (e.g. unoccupied room)
 - operation of the heat pump with the fan at low speed to reduce the noise level.
- Master/slave control of two heat pumps operating in parallel with operating time equalisation.
- RS 485 serial port for remote heat pump control via communications bus.



PRO-DIALOG Plus operator interface

Options and accessories

	Option	Accessory
Fan with available pressure for discharge ducting (30RH 090-240)	x	
Unit with very low noise level	x	
Condenser anti-corrosion pre-treatment for marine applications	x	
Electronic compressor starter for reduction of start-up current (30RH 040-080)	x	
Unit without hydronic module	x	
Hydronic module with dual pump	x	
Supplementary electric resistance heater control board (3 stages + 1 emergency stage)		x
Communications board with JBus or Bacnet or LonTalk protocol		x

Hydronic module (040 to 160)

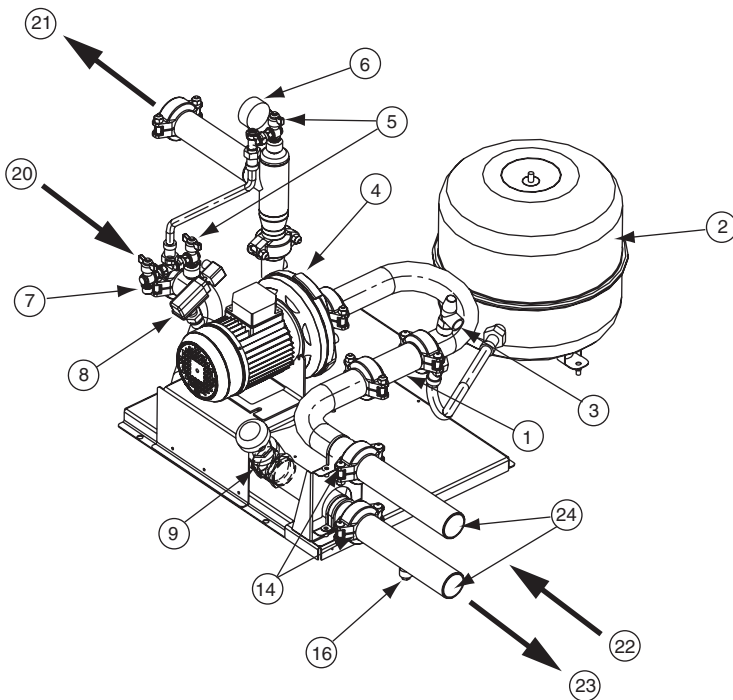

Legend

Components of unit and hydronic module

- 1 Victaulic screen filter
- 2 Expansion tank
- 3 Safety valve
- 4 Available pressure pump
- 5 Purge valve and pressure tap (see Installation Manual)
- 6 Pressure gauge to measure the plate heat exchanger pressure drop (to be isolated with valve No. 5 if not used)
- 7 System air vent
- 8 Flow switch
- 9 Flow control valve
- 10 Plate heat exchanger
- 11 Evaporator defrost heater

Installation components

- 12 Air vent
- 13 Thermometer sleeve
- 14 Flexible connection
- 15 Check valve
- 16 System water drain plug (on connection pipe supplied in the unit)
- 17 Pressure gauge
- 18 Freeze-up protection bypass valve (when valves No. 15 are closed during winter)
- 19 Charge valve
- 20 Plate heat exchanger outlet
- 21 Plate heat exchanger inlet
- 22 Water inlet
- 23 Water outlet
- 24 Customer connection sleeves for welded or screw connection (supplied)
- Hydronic module (units with hydronic module)

Note: Units without hydronic module (option) are equipped with a flow switch and an internal piping heater.

Typical hydronic circuit diagram

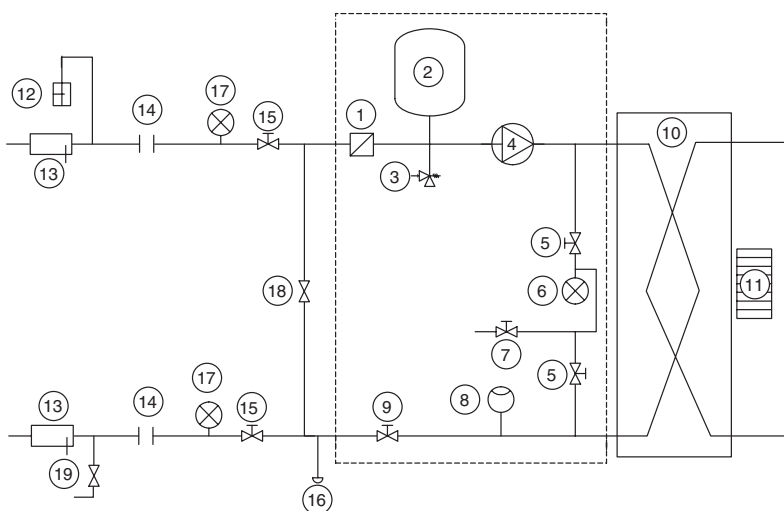

Physical data

30RH		040	050	060	070	080	090	100	120	140	160	200	240
Nominal cooling capacity*	kW	38.3	43.6	54.0	66.0	71.0	83.0	92.0	106.0	132.0	142.0	179.0	210.0
Nominal heating capacity**	kW	38.4	44.6	57.0	65.0	78.0	85.0	96.0	116.0	130.0	153.0	194.0	229.0
Seasonal energy efficiency (ESEER)	kW/kW	3.01	2.58	2.85	3.58	3.21	3.72	3.47	3.71	3.64	3.34	3.20	3.09
Operating weight, with hydronic module	kg												
Single pump		566	624	647	661	691	1183	1196	1238	1312	1368	2233	2405
Dual pump		646	704	727	741	768	1260	1273	1338	1412	1468	2321	2493
Unit without hydronic module		542	600	623	637	665	1152	1165	1200	1274	1330	2086	2258
Refrigerant charge	kg												
		R-407C											
Circuit A		10.9	11.5	15.1	16.7	19.5	11.4	11.8	15.6	17.4	20.3	22.5	29.5
Circuit B		-	-	-	-	-	12.0	15.6	15.6	17.4	20.3	29.5	29.5
Compressors		Hermetic scroll compressor, 48.3 r/s											
Quantity, circuit A		1	2	2	2	2	1	1	2	2	2	2	3
Quantity, circuit B		-	-	-	-	-	2	2	2	2	2	3	3
No. of capacity steps		1	2	2	2	2	3	3	4	4	4	5	6
Minimum capacity	%	100	46	42	50	50	25	25	21	25	25	20	16.5
Control type		PRO-DIALOG Plus											
Air heat exchangers		Grooved copper tubes, aluminium fins											
Fans		Axial Flying Bird II fans with rotating shroud											
Quantity		1	1	1	1	1	2	2	2	2	2	4	4
Total air flow (high speed)	l/s	3870	3660	4080	5600	5600	7350	7950	8160	11200	11200	17343	20908
Speed (high/low speed)	r/s	11.5/5.8	11.5/5.8	11.5/5.8	15.6/7.8	15.6/7.8	11.5/5.8	11.5/5.8	11.5/5.8	15.6/7.8	15.6/7.8	11.5/5.8	15.6/7.8
Water heat exchangers		Direct-expansion welded plate heat exchanger											
Water volume	l	3.6	4.6	5.9	6.5	7.6	7.2	8.2	9.8	11.4	13.0	26.8	26.8
Max. water-side operating pressure	kPa												
Option without hydronic module		1000	1000	1000	1000	1000	1000	1000	1000	1000	1000	1000	1000
Unit with hydronic module		300	300	300	300	300	300	300	300	300	300	400	400
Hydronic module		Monocell composite pump											
Pump (single centrifugal, 48.3 r/s)													Monocell pump
Quantity		1	1	1	1	1	1	1	1	1	1	1	1
Expansion tank volume	l	12	12	12	12	12	35	35	35	35	35	50	50
Expansion tank pressure	kPa	100	100	100	100	100	150	150	150	150	150	150	150
Water connections (with and without hydronic module)		Victaulic (sleeves for welding or screw connections supplied)											
Diameter	in	2	2	2	2	2	2	2	2-1/2	2-1/2	2-1/2	3	3
Outside tube diameter	mm	60.3	60.3	60.3	60.3	60.3	60.3	60.3	76.1	76.1	76.1	88.9	88.9

Legend

* Nominal conditions: water heat exchanger entering/leaving temperature 12°C/7°C, outdoor air temperature 35°C.

** Nominal conditions: air heat exchanger entering/leaving temperature 40°C/45°C, outdoor air dry bulb temperature 7°C.

Sound levels

30RH		040	050	060	070	080	090	100	120	140	160	200	240
Sound power, dB(A) 10⁻¹² W		82	82	82	86	87	85	85	85	89	90	91	92

According to Eurovent 8/1 (derived from ISO standard 3744 or ISO 9614-1).

Electrical data

30RH (without hydronic module)		040	050	060	070	080	090	100	120	140	160	200	240
Power circuit													
Nominal power supply	V-ph-Hz	400-350											
Voltage range	V	360-440											
Control circuit supply													
The control circuit is supplied via the unit-mounted transformer													
Maximum unit power input*	kW	20.3	24.6	30.1	35.2	40.0	44.2	49.6	60.5	70.7	79.7	104.3	124.9
Nominal unit current draw**	A	28.0	34.7	41.2	47.0	54.3	62.7	69.1	82.3	94.1	108.6	140.3	168.7
Maximum unit current draw at 360 V***	A	37.0	45.7	54.9	62.7	72.4	82.6	91.9	109.8	125.4	144.8	185.4	222.9
Maximum unit current draw at 400 V****	A	33.6	41.4	49.7	57.0	65.7	75.1	83.4	99.5	113.9	131.3	168.7	202.8
Maximum start-up current													
Standard unit†	A	158.4	151.0	168.9	176.1	190.4	199.8	208.1	218.6	233.0	256.1	293.4	327.6
With electronic starter control‡	A	99.0	101.0	113.0	120.0	132.0	-	-	-	-	-	-	-
Holding current for three-phase short circuits	kA	6	6	6	6	6	10	10	10	10	10	19	19

* Power input of the compressor(s) + fan(s) at maximum unit operating conditions: entering/leaving water temperature = 15°C/10°C, maximum condensing temperature of 67.8°C and 400 V nominal voltage (values given on the unit name plate).

** Nominal unit operating current draw at the following conditions: evaporator entering/leaving water temperature 12°C/7°C, outdoor air temperature 35°C. The current values are given at 400 V nominal voltage.

*** Maximum unit operating current at maximum unit power input and 360 V nominal voltage.

**** Maximum unit operating current at maximum unit power input and 400 V nominal voltage (values given on the unit name plate).

† Maximum instantaneous starting current at 400 V nominal voltage and with compressor in across-the-line-start (maximum operating current of the smallest compressor(s) + fan current + locked rotor current of the largest compressor).

‡ Maximum instantaneous starting current at 400 V nominal voltage and with compressor with electronic starter (maximum operating current of the smallest compressor(s) + fan current + reduced start-up current of the largest compressor).

Hydronic module		040	050	060	070	080	090	100	120	140	160	200	240
Single pump													
Shaft power	kW	0.75	0.75	0.75	0.75	1.1	1.1	1.1	1.85	1.85	1.85	5.5	5.5
Power input*	kW	1.1	1.1	1.1	1.1	1.4	1.4	1.4	2.5	2.5	2.5	6.6	6.6
Maximum current draw at 400 V**	A	2.1	2.1	2.1	2.1	3.1	3.1	3.1	5.0	5.0	5.0	10.6	10.6
Dual pump													
Shaft power	kW	2.2	2.2	2.2	2.2	2.2	2.2	2.2	3.0	3.0	3.0	5.5	5.5
Power input*	kW	2.7	2.7	2.7	2.7	2.7	2.7	2.7	4.0	4.0	4.0	6.6	6.6
Maximum current draw at 400 V**	A	4.7	4.7	4.7	4.7	4.7	4.7	4.7	6.6	6.6	6.6	10.6	10.6

Note: The water pump power input values are given for guidance only.

* To obtain the maximum power input for a unit with hydronic module add the maximum unit power input from the top table to the pump power input (*) from the table above.

** To obtain the maximum unit operating current draw for a unit with hydronic module add the maximum unit current draw from the top table to the pump current draw from the table above.

Electrical data notes:

- 30RH 040-240 units have a single power connection point located at the main switch.
- The control box includes the following standard features:
 - a main disconnect switch, starter and motor protection devices for each compressor, the fan, the optional pumps
 - the control devices
- Field connections:
 - All connections to the system and the electrical installations must be in full accordance with all applicable local codes.
- The Carrier 30RH units are designed and built to ensure conformance with these codes. The recommendations of European standard EN 60204-1 (corresponds to IEC 60204-1) (machine safety - electrical machine components - part 1: general regulations) are specifically taken into account, when designing the electrical equipment.

NOTES:

- Generally the recommendations of IEC 60364 are accepted as compliance with the requirements of the installation directives. Conformance with EN 60204-1 is the best means of ensuring compliance with the Machines Directive § 1.5.1.
- Annex B of EN 60204-1 describes the electrical characteristics used for the operation of the machines.

1. The operating environment for the 30RH units is specified below:
 - a. Environment* - Environment as classified in EN 60721 (corresponds to IEC 60721):
 - outdoor installation*
 - ambient temperature range: -10°C to +45°C ± 1 K, class 4K3*
 - altitude: ≤ 2000 m
 - presence of hard solids, class 4S2 (no significant dust present)
 - presence of corrosive and polluting substances, class 4C2 (negligible)
 - vibration and shock, class 4M2
 - b. Competence of personnel, class BA4* (trained personnel - IEC 60364)
2. Power supply frequency variation: ± 2 Hz.
3. The neutral (N) conductor must not be connected directly to the unit (if necessary use transformers)
4. Over-current protection of the power supply conductors is not provided with the unit.
5. The factory-installed disconnect switches/circuit breakers are of a type that is suitable to interrupt the power in accordance with EN60947-3 (corresponds to IEC 60947-3).
6. The units are designed for connection to TN networks (IEC 60364). For IT networks the earth connection must not be at the network earth. Provide a local earth, consult competent local organisations to complete the electrical installation.

NOTE:

If particular aspects of an actual installation do not conform to the conditions described above, or if there are other conditions which should be considered, always contact your local Carrier representative.

- * The required protection level for this class is IP43BW (according to reference document IEC 60529). All 30RH units are protected to IP44CW and fulfil this protection condition.

Operating limits

30RH	Evaporator water flow rate, l/s				
	Min. water flow		Max. water flow*		Max. water flow**
			Single pump	Dual pump	
040	1.0		3.5	4.4	3.7
050	1.1		4.0	5.2	4.6
060	1.4		4.4	6.0	5.8
070	1.5		4.6	6.4	6.4
080	1.7		5.5	6.8	7.3
090	2.3		5.6	6.9	7.6
100	2.6		5.8	7.4	8.8
120	3.1		8.5	10.5	10.8
140	3.5		8.8	11.4	12.7
160	4.2		9.1	11.9	14.4
200	5.3		23.4	23.4	24.2
240	6.3		23.4	23.4	24.2

30RH 040-240	Heating mode							
	Entering water temperature at start-up, °C		Entering water temperature at shut-down, °C		Leaving water temperature during operation		Entering air temperature, °C	
	Minimum†	Maximum	Minimum	Maximum	Minimum‡	Maximum	Minimum	Maximum
	10	45	3	60	20	50	-10	40

30RH 040-240	Cooling mode							
	Entering water temperature at start-up, °C		Entering water temperature		Leaving water temperature at shut-down, °C		Entering air temperature, °C during operation	
	Minimum†	Maximum	Maximum		Minimum‡	Maximum	Minimum	Maximum
	7.8	30	60		5	15	-10	46

Notes:

- * Maximum flow rate for an available pressure of 50 kPa (unit with hydronic module)
- ** Maximum flow rate for a pressure drop of 100 kPa (unit without hydronic module)
- † For applications requiring operation below 7.8°C contact Carrier
- ‡ For applications requiring operation below 5°C anti-freeze must be used

Operating range in cooling mode

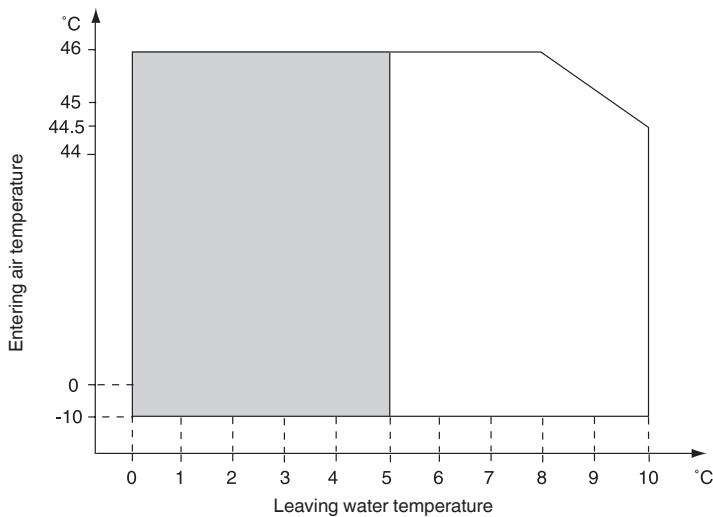

Operating range in heating mode

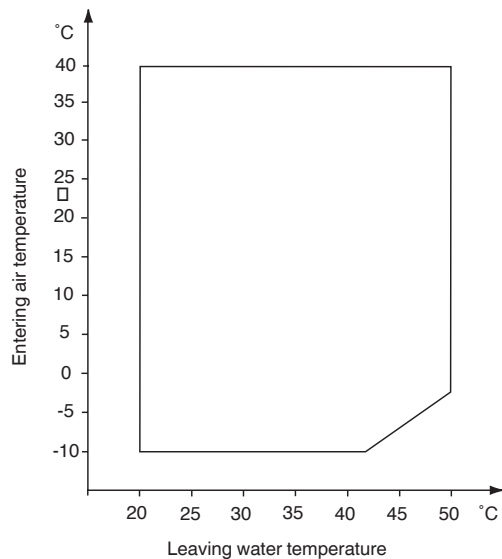

Notes:

1. Water heat exchanger $\Delta t = 5$ K
2. The water heat exchanger and the hydronic module are protected against frost down to -20°C.

■ Operating range with required anti-freeze solution and special Pro-Dialog control configuration

Available static system pressure

Single pump

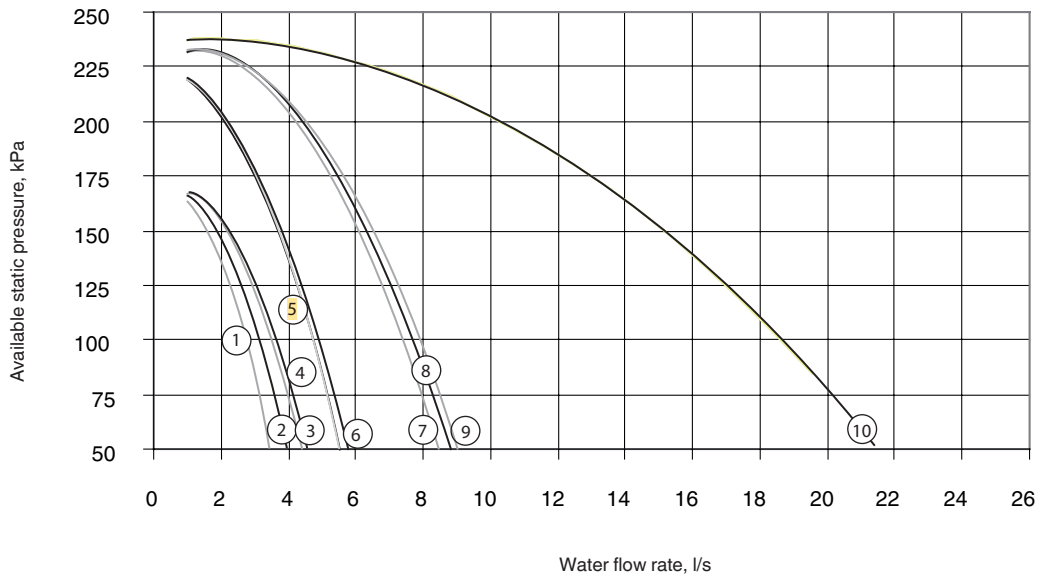

Legend

- | | |
|----------------|-----------------|
| 1 30RH 040 | 6 30RH 100 |
| 2 30RH 050 | 7 30RH 120 |
| 3 30RH 060 | 8 30RH 140 |
| 4 30RH 070 | 9 30RH 160 |
| 5 30RH 080-090 | 10 30RH 200-240 |

Dual pump

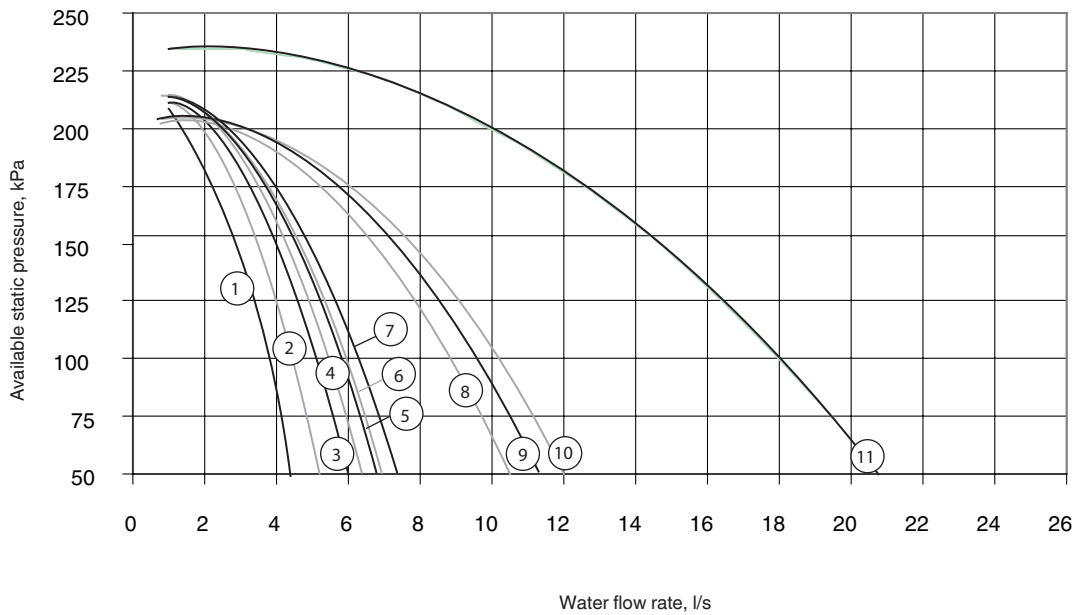

Legend

- | | |
|------------|-----------------|
| 1 30RH 040 | 7 30RH 100 |
| 2 30RH 050 | 8 30RH 120 |
| 3 30RH 060 | 9 30RH 140 |
| 4 30RH 070 | 10 30RH 160 |
| 5 30RH 080 | 11 30RH 200-240 |
| 6 30RH 090 | |

30RH		Entering air temperature, °C																																		
LWT	°C	-10					-5					0					7					10														
		CAP	COMP	UNIT	COND	PRES	PRES	CAP	COMP	UNIT	COND	PRES	PRES	CAP	COMP	UNIT	COND	PRES	PRES	CAP	COMP	UNIT	COND	PRES	PRES	CAP	COMP	UNIT	COND	PRES	PRES					
		kW	kW	kW	l/s	kPa	kPa	kPa	kW	kW	kW	l/s	kPa	kPa	kPa	kW	kW	kW	l/s	kPa	kPa	kPa	kW	kW	kW	l/s	kPa	kPa	kPa	kW	kW	kW	l/s	kPa	kPa	kPa
040	30	22.3	8.97	10.2	1.06	9	162	208	25.4	9.03	10.2	1.21	12	159	205	30.4	9.41	10.6	1.45	17	154	201	41.3	10.4	11.6	1.97	32	137	186	44.7	10.5	11.7	2.14	38	130	181
050		26.1	12.3	13.5	1.25	8	163	209	29.8	12.4	13.6	1.42	10	160	207	35.6	12.9	14.1	1.7	15	155	203	51	13.7	14.9	2.45	31	132	185	55	13.9	15.1	2.61	35	126	180
060		33	13.7	14.9	1.58	8	162	209	37.7	13.8	15	1.8	11	158	206	45	14.3	15.5	2.15	15	151	201	61	15.1	16.3	2.92	28	127	185	66	15.3	16.5	3.14	32	118	179
070		37.7	15	17.5	1.8	9	160	208	43	15.2	17.7	2.06	11	155	205	51	15.8	18.3	2.46	16	145	198	68	17.2	19.7	3.26	28	118	181	74	17.5	20	3.53	33	106	173
080		45.1	18.3	20.8	2.16	10	200	206	52	18.5	21	2.46	13	193	202	62	19.2	21.7	2.94	18	178	193	83	20.3	22.8	3.97	33	138	168	89	20.6	23.1	4.26	38	124	160
090		49.5	20.5	22.9	2.36	12	195	203	56	20.6	23	2.7	16	185	197	67	21.5	23.9	3.22	22	168	187	95	23.1	25.5	4.52	41	112	152	102	23.5	25.9	4.85	47	94	141
100		56	22.7	25.1	2.66	12	190	201	63	22.8	25.2	3.03	15	179	195	76	23.7	26.1	3.62	21	159	184	103	25.4	27.8	4.92	37	101	149	111	25.8	28.2	5.31	42	81	137
120		67	27.4	29.8	3.22	12	217	196	77	27.6	30	3.67	15	210	192	92	28.6	31	4.38	21	197	185	125	30.2	32.6	5.96	36	154	163	134	30.6	33	6.4	41	139	156
140		75	30.1	35.1	3.6	11	215	196	86	30.3	35.3	4.11	14	206	192	103	31.6	36.6	4.91	19	190	185	137	34.4	39.4	6.53	32	144	163	148	35	40	7.07	37	126	154
160		89	36.3	41.3	4.23	12	207	194	101	36.6	41.6	4.83	15	195	189	121	38.1	43.1	5.77	21	173	179	163	40.1	45.1	7.78	36	106	149	175	40.7	45.7	8.36	41	82	138
200		115	46.5	54	5.48	7	230	228	138	47.6	55	6.57	10	225	223	163	49.3	57	7.8	13	219	216	204	47.2	55	9.74	20	205	202	216	47.6	55	10.3	23	200	197
240		138	60	70	6.59	10	225	223	157	60	70	7.52	13	220	218	188	63	73	8.98	17	211	208	248	57	68	11.9	29	186	182	267	58	68	12.7	33	177	173
040	35	21.9	9.87	11.1	1.05	9	162	208	25.1	9.94	11.1	1.2	12	160	206	30	10.3	11.5	1.44	17	154	201	40	11.4	12.6	1.91	30	140	188	43.5	11.6	12.8	2.08	36	133	183
050		25.7	13.5	14.7	1.23	8	163	209	29.4	13.6	14.8	1.4	10	161	207	35.2	14.1	15.3	1.68	15	155	203	48.7	15.2	16.4	2.32	28	137	189	52	15.4	16.6	2.48	32	131	184
060		32.5	15	16.2	1.55	8	162	209	37.2	15.1	16.3	1.78	10	159	207	44.5	15.6	16.8	2.13	15	151	201	59	16.8	18	2.84	26	130	187	64	17	18.2	3.05	30	121	181
070		37.1	16.6	19.1	1.77	8	160	208	42.4	16.7	19.2	2.03	11	156	205	51	17.4	19.9	2.43	16	146	199	67	19	21.5	3.21	28	120	182	73	19.3	21.8	3.48	32	109	175
080		44.5	20.2	22.7	2.12	9	201	206	51	20.3	22.8	2.43	12	193	202	61	21.1	23.6	2.91	18	179	194	81	22.6	25.1	3.85	31	143	172	87	22.9	25.4	4.14	36	130	163
090		48.7	22.5	24.9	2.33	12	195	203	56	22.7	25.1	2.66	15	186	198	67	23.5	25.9	3.19	21	169	188	91	25.6	28	4.33	38	121	158	98	26	28.4	4.66	44	104	148
100		55	24.9	27.3	2.62	11	191	202	63	25	27.4	2.99	15	180	196	75	25.9	28.3	3.58	20	160	185	100	28.2	30.6	4.78	35	108	154	108	28.6	31	5.16	40	88	141
120		66	30	32.4	3.17	11	218	196	76	30.2	32.6	3.62	14	211	193	91	31.3	33.7	4.34	20	198	186	121	33.6	36	5.79	34	159	166	130	34.1	36.5	6.23	39	145	159
140		74	33.2	38.2	3.55	10	216	196	85	33.4	38.4	4.06	13	207	193	102	34.7	39.7	4.86	19	191	185	134	38.1	43.1	6.42	31	148	165	146	38.6	43.6	6.96	36	130	156
160		87	40	45	4.16	11	208	194	100	40.3	45.3	4.76	14	197	189	119	41.8	46.8	5.7	20	174	180	158	44.7	49.7	7.55	34	115	153	170	45.3	50	8.12	38	92	143
200		113	51	59	5.4	7	230	228	136	53	60	6.49	10	226	223	162	54	62	7.72	13	219	217	200	52	60	9.54	20	207	204	212	53	60	10.1	22	202	199
240		136	65	75	6.49	10	226	223	155	66	76	7.42	12	221	218	186	68	78	8.88	17	211	209	241	63	74	11.5	28	190	186	259	64	74	12.4	32	181	177
040	40	21.3	10.9	12.1	1.02	9	163	208	24.5	11	12.2	1.17	11	160	206	29.4	11.4	12.6	1.41	16	155	202	39.1	12.6	13.8	1.87	29	141	190	42.5	12.8	14	2.03	34	135	184
050		25	15	16.2	1.2	7	164	210	28.7	15.1	16.3	1.37	10	161	208	34.5	15.6	16.8	1.65	14	156	203	46.4	16.9	18.1	2.22	25	141	191	49.7	17.1	18.3	2.38	29	135	187
060		31.6	16.6	17.8	1.51	7	163	210	36.3	16.7	17.9	1.73	10	159	207	43.6	17.2	18.4	2.08	14	152	202	58	18.7	19.9	2.77	25	132	188	62	18.9	20.1	2.98	29	124	183
070		36.1	18.5	21	1.73	8	161	209	41.4	18.6	21.1	1.98	11	157	206	49.8	19.2	21.7	2.38	15	148	200	66	21.1	23.6	3.15	27	122	184	72	21.4	23.9	3.42	31	111	177
080		43.2	22.4	24.9	2.07	9	202	207	49.6	22.5	25	2.37	12	195	203	60	23.3	25.8	2.85	17	181	195	79	25.2	27.7	3.76	30	147	174	85	25.5	28	4.06	34	133	166
090		47.4	24.9	27.3	2.26	11	197	204	54	25.1	27.5	2.6	15	188	199	65	25.9	28.3	3.12	21	172	189	87	28.4	30.8	4.18	36	129	163	94	28.8	31.2	4.51	41	113	153
100		53	27.5	29.9	2.55	11	193	203	61	27.7	30.1	2.92	14	182	197	73	28.6	31	3.51	20	163	186	98	31.3	33.7	4.66	33	114	157	106	31.7	34.1	5.05	39	95	145
120		64	33.1	35.5	3.08	11	219	197	74	33.3	35.7	3.54	14	213	193	89	34.4	36.8	4.25	19	199	187	118	37.4	39.8	5.65	33	164	168	127	37.8	40.2	6.09	38	150	161
140		72	36.9	41.9	3.45	10	217	197	83	37.1	42.1	3.96	13	209	193	100	38.4	43.4	4.76	18	193	186	132	42.2	47.2	6.31	30	152	166	143	42.7	47.7	6.85	35	134	158
160		85	44.3	49.3	4.05	11	210	195	97	44.6	49.6	4.65	14	199	190	117	46.1	51	5.59	19	177	181	155	49.9	55	7.38	32	121	156	167	50	55	7.96	37	99	146
200		111	57	65	5.31	7	231	229	134	58	66	6.4	9	226	224	160	60	67	7.63	13	220	217	196	58	66	9.38	19	208	205	208	59	66	9.96	21	203	200
240		132	72	82	6.31	9	226	224	152	72	82	7.24	12	222	220	182	74	84	8.71	16	213	210	235	70	80	11.2	26	192	189	253	71	81	12.1	30	184	180

Heating capacities, single and dual pumps

30RH		Entering air temperature, °C																																	
LWT	°C	-10						-5						0						7						10									
		CAP	COMP	UNIT	COND	PRES (1)	PRES (2)	CAP	COMP	UNIT	COND	PRES (1)	PRES (2)	CAP	COMP	UNIT	COND	PRES (1)	PRES (2)	CAP	COMP	UNIT	COND	PRES (1)	PRES (2)	CAP	COMP	UNIT	COND	PRES (1)	PRES (2)				
040	45							23.6	12.2	13.4	1.13	10	161	207	28.6	12.6	13.8	1.37	15	156	202	38.4	13.9	15.1	1.84	28	142	191	41.9	14.1	15.3	2	33	136	185
050								27.7	16.7	17.9	1.32	9	162	208	33.5	17.2	18.4	1.6	13	157	204	44.6	18.7	19.9	2.13	23	143	194	47.9	18.9	20.1	2.29	27	138	190
060								35	18.4	19.6	1.67	9	160	208	42.4	19	20.2	2.02	13	154	203	57	20.8	22	2.71	24	134	190	61	21	22.2	2.93	28	126	184
070								40	20.7	23.2	1.91	10	158	207	48.4	21.3	23.8	2.31	14	149	201	65	23.3	25.8	3.1	26	124	185	70	23.6	26.1	3.37	30	114	178
080								47.9	25	27.5	2.29	11	197	204	58	25.8	28.3	2.77	16	184	197	78	28.1	30.6	3.72	29	149	175	84	28.4	30.9	4.01	34	136	167
090								52	27.8	30.2	2.51	14	191	200	63	28.7	31.1	3.03	20	175	191	85	31.4	33.8	4.05	34	134	166	92	31.8	34.2	4.38	39	119	157
100								59	30.7	33.1	2.82	13	185	199	71	31.6	34	3.41	19	166	188	96	34.7	37.1	4.57	32	118	160	104	35.1	37.5	4.96	37	99	148
120								71	36.9	39.3	3.41	13	215	194	86	38	40.4	4.13	18	202	188	116	41.5	43.9	5.53	32	167	170	125	42	44.4	5.97	36	154	163
140								80	41.4	46.4	3.82	12	211	194	97	42.7	47.7	4.62	17	196	187	130	46.7	52	6.19	29	155	168	141	47.3	52	6.73	34	138	160
160								94	49.6	55	4.49	13	202	192	114	51	56	5.43	18	181	183	153	56	61	7.3	32	124	157	165	56	61	7.87	36	102	147
200								132	65	72	6.3	9	227	224	158	66	74	7.53	13	220	218	194	65	73	9.28	19	209	206	206	65	73	9.86	21	204	201
240								146	79	89	6.99	11	223	221	177	81	91	8.46	16	214	212	229	78	88	11	25	195	191	248	79	89	11.8	29	187	183
040	50														27.5	14	15.2	1.31	14	157	204	38.1	15.4	16.6	1.82	27	143	191	41.5	15.6	16.8	1.98	32	137	186
050															32.2	19	20.2	1.54	12	158	205	43.2	20.6	21.8	2.06	22	146	195	46.5	20.9	22.1	2.22	25	140	191
060															40.7	21	22.2	1.95	12	155	204	56	23	24.2	2.67	23	136	191	60	23.2	24.4	2.88	27	128	186
070															46.5	23.7	26.2	2.22	13	151	202	64	25.8	28.3	3.04	25	127	186	69	26.1	28.6	3.31	29	116	180
080															56	28.7	31.2	2.66	15	187	198	78	31.3	33.8	3.72	29	149	175	84	31.6	34.1	4.01	34	136	167
090															61	31.8	34.2	2.92	18	178	193	83	34.7	37.1	3.97	32	138	169	90	35.1	37.5	4.3	38	123	159
100															69	35	37.4	3.28	17	171	191	94	38.5	40.9	4.51	31	121	161	102	38.9	41.3	4.89	37	102	150
120															83	42	44.4	3.97	17	205	189	114	46	48.4	5.44	31	170	171	123	46.5	48.9	5.88	35	157	165
140															93	47.5	52	4.44	16	200	189	127	52	57	6.07	28	159	170	138	52	57	6.61	33	142	162
160															109	57	62	5.22	17	186	185	152	62	67	7.29	32	125	157	165	63	68	7.86	36	103	148
200															155	74	81	7.42	12	221	218	193	73	80	9.23	18	209	206	205	73	80	9.81	21	204	202
240															170	89	100	8.13	15	216	214	225	86	97	10.8	24	197	193	243	87	97	11.6	28	189	185

Legend:
LWT Leaving water temperature
CAP kW Instantaneous heating capacity
COMP kW Compressor power input
UNIT kW Unit power input, (compressors, fans and control circuit)
COND l/s Condenser water flow rate
COND kPa Condenser pressure drop
PRES kPa (1) Available pressure at the unit outlet (unit with single-pump hydronic module)
PRES kPa (2) Available pressure at the unit outlet (unit with dual-pump hydronic module)

Application data:
 Standard units
 Refrigerant: R-407C
 Condenser temperature rise: 5 K
 Condenser fluid: water
 Fouling factor: 0.44 x 10⁻⁴ (m² K)/W

Performances in accordance with EN 14511.

Heating capacity at low outdoor temperature
 The published heating capacities are instantaneous capacities. They do not take account of the decrease of the heating capacity, resulting from the formation of frost on the coil and the effect of the defrost cycles. The integrated heating capacity takes these effects into account. They depend on the temperature and the relative humidity (rh) of the outdoor air.

Correction factor to obtain integrated heating capacities

Leaving water temp. °C	Outdoor temperature °C (87% rh)				
	-10	-5	0	7	10
30	0.88	0.85	0.87	1	1
35	0.87	0.85	0.87	1	1
40	0.88	0.85	0.87	1	1
45	0.89	0.86	0.88	1	1
50	0.91	0.89	0.91	1	1

Note:
 The Carrier electronic selection program permits calculating the integrated heating capacity as a function of the actual humidity conditions at the installation site. Contact Carrier for your personalised heat pump

30RH		Condenser entering air temperature, °C																																		
LWT	°C	25						30						35						40						45										
		CAP	COMP	UNIT	COOL	COOL	PRES	PRES	CAP	COMP	UNIT	COOL	COOL	PRES	PRES	CAP	COMP	UNIT	COOL	COOL	PRES	PRES	CAP	COMP	UNIT	COOL	COOL	PRES	PRES	CAP	COMP	UNIT	COOL	COOL	PRES	PRES
						(1) (2)						(1) (2)						(1) (2)						(1) (2)						(1) (2)						
		kW	kW	kW	l/s	kPa	kPa	kPa	kW	kW	kW	l/s	kPa	kPa	kPa	kW	kW	kW	l/s	kPa	kPa	kPa	kW	kW	kW	l/s	kPa	kPa	kPa	kW	kW	kW	l/s	kPa	kPa	kPa
040	5	40.1	10.7	11.9	1.91	30	140	188	37.9	11.8	13	1.81	27	143	191	35.7	13	14.2	1.71	24	147	194	33.6	14.3	15.5	1.61	21	150	197	31.6	15.7	16.9	1.51	19	153	199
050		45.8	14.4	15.6	2.19	25	141	192	43.3	16	17.2	2.07	22	145	195	40.8	17.8	19	1.95	20	149	198	38.3	19.6	20.8	1.83	17	152	200	35.7	21.5	22.7	1.71	15	155	202
060		57	16.3	17.5	2.7	24	134	190	54	18	19.2	2.56	21	139	193	51	19.9	21.1	2.41	19	144	196	47.5	21.8	23	2.27	17	148	199	44.5	23.9	25.1	2.13	15	151	201
070		69	18.8	21.3	3.28	29	117	180	65	20.7	23.2	3.12	26	124	184	62	22.8	25.3	2.95	23	130	188	58	24.9	27.4	2.78	21	136	192	55	27.3	29.8	2.6	18	141	196
080		75	23.4	25.9	3.58	27	154	179	71	25.9	28.4	3.39	24	162	184	67	28.5	31	3.19	21	169	188	63	31.3	33.8	2.99	19	176	192	58	34.3	36.8	2.79	16	183	196
090		87	24.1	26.5	4.15	35	130	164	82	26.8	29.2	3.92	32	140	170	77	29.6	32	3.7	28	150	176	73	32.6	35	3.47	25	159	182	68	35.8	38.2	3.25	22	167	187
100		97	27	29.4	4.62	33	116	158	91	29.8	32.2	4.37	30	128	166	86	32.9	35.3	4.12	27	139	172	81	36.1	38.5	3.88	24	149	178	76	39.6	42	3.63	21	158	184
120		111	32.6	35	5.3	29	174	173	105	36.1	38.5	5.02	26	181	177	99	39.8	42.2	4.73	24	189	181	93	43.6	46	4.45	21	195	184	87	47.8	50	4.17	19	201	187
140		137	37.7	42.7	6.57	33	143	162	130	41.4	46.4	6.23	30	154	168	123	45.5	51	5.9	27	164	172	116	49.9	55	5.56	24	174	177	109	55	60	5.21	21	183	181
160		150	46.4	51	7.16	31	129	159	142	51	56	6.77	28	142	165	133	56	61	6.38	25	155	171	125	62	67	5.98	22	167	176	117	68	73	5.58	19	177	181
200		187	54	61	8.95	17	211	208	177	59	67	8.47	16	214	212	167	65	73	7.99	14	217	215	157	72	79	7.52	13	220	218	148	79	86	7.05	11	223	221
240		221	65	75	10.6	24	198	195	209	72	82	9.99	21	203	200	197	79	89	9.42	19	207	205	185	87	97	8.85	17	212	209	173	96	106	8.27	15	216	213
040	6	41.5	10.8	12	1.98	32	137	186	39.2	11.9	13.1	1.87	29	141	190	37	13.2	14.4	1.77	26	145	193	34.8	14.5	15.7	1.66	23	148	196	32.7	15.8	17	1.56	20	151	198
050		47.3	14.6	15.8	2.26	26	139	190	44.7	16.2	17.4	2.14	24	143	193	42.2	18	19.2	2.02	21	147	196	39.6	19.8	21	1.89	18	150	199	37	21.7	22.9	1.77	16	153	201
060		58	16.5	17.7	2.79	25	131	188	55	18.3	19.5	2.64	23	136	191	52	20.1	21.3	2.5	20	141	194	49.1	22.1	23.3	2.35	18	145	197	46.1	24.1	25.3	2.2	16	149	200
070		71	19.1	21.6	3.39	31	113	177	67	21	23.5	3.22	28	120	182	64	23	25.5	3.05	25	126	186	60	25.2	27.7	2.87	22	133	190	56	27.5	30	2.7	20	138	194
080		77	23.7	26.2	3.7	29	150	176	73	26.2	28.7	3.49	25	158	181	69	28.8	31.3	3.29	23	166	186	65	31.7	34.2	3.09	20	173	190	60	34.7	37.2	2.89	17	180	194
090		90	24.5	26.9	4.29	37	123	160	85	27.1	29.5	4.05	34	134	166	80	29.9	32.3	3.82	30	144	173	75	32.9	35.3	3.6	27	154	179	71	36.1	38.5	3.37	24	163	184
100		100	27.3	29.7	4.77	35	108	154	95	30.2	32.6	4.52	31	121	161	89	33.3	35.7	4.26	28	132	168	84	36.5	38.9	4.01	25	143	175	79	40	42.4	3.76	22	153	181
120		115	33	35.4	5.47	31	169	171	108	36.5	38.9	5.18	28	177	175	102	40.2	42.6	4.89	25	185	179	96	44.1	46.5	4.6	23	192	183	90	48.3	51	4.31	20	198	186
140		142	38.1	43.1	6.79	35	136	159	135	41.9	46.9	6.45	31	147	164	128	46	51	6.1	28	158	170	120	50	55	5.75	25	168	174	113	55	60	5.39	23	178	179
160		155	47	52	7.39	32	121	156	146	52	57	6.99	29	135	162	138	57	62	6.58	26	148	168	129	63	68	6.18	23	161	174	121	69	74	5.77	21	172	179
200		194	55	62	9.26	18	209	206	183	60	68	8.76	17	212	210	173	66	74	8.27	15	216	213	163	73	80	7.79	13	219	216	153	80	87	7.31	12	221	219
240		228	66	76	10.9	25	195	192	216	73	83	10.3	23	200	197	204	80	90	9.74	20	205	202	191	88	98	9.15	18	210	207	179	97	107	8.56	16	214	211
040	7	42.9	11	12.2	2.05	34	134	184	40.6	12.1	13.3	1.94	31	139	187	38.3	13.3	14.5	1.83	27	143	191	36.1	14.6	15.8	1.72	24	146	194	33.9	16	17.2	1.62	22	149	197
050		48.7	14.8	16	2.33	28	137	188	46.2	16.4	17.6	2.21	25	141	192	43.6	18.2	19.4	2.08	22	145	195	41	20	21.2	1.96	20	148	197	38.4	21.9	23.1	1.83	17	152	200
060		60	16.7	17.9	2.88	27	128	186	57	18.5	19.7	2.73	24	134	189	54	20.3	21.5	2.58	22	139	193	51	22.3	23.5	2.43	19	143	196	47.6	24.4	25.6	2.28	17	147	199
070		73	19.3	21.8	3.5	33	108	174	70	21.2	23.7	3.33	30	115	179	66	23.3	25.8	3.15	27	122	184	62	25.5	28	2.97	24	129	188	58	27.8	30.3	2.79	21	135	192
080		80	24.1	26.6	3.81	30	145	173	75	26.5	29	3.6	27	153	178	71	29.2	31.7	3.4	24	162	183	67	32	34.5	3.19	21	169	188	62	35	37.5	2.98	19	177	193
090		93	24.8	27.2	4.42	40	117	155	88	27.4	29.8	4.19	36	128	163	83	30.3	32.7	3.95	32	139	169	78	33.3	35.7	3.72	29	149	175	73	36.4	38.8	3.49	25	158	181
100		103	27.7	30.1	4.93	37	101	149	98	30.6	33	4.67	33	114	157	92	33.6	36	4.41	30	126	164	87	36.9	39.3	4.15	27	137	171	81	40.4	42.8	3.89	24	148	178
120		118	33.4	35.8	5.65	33	164	168	112	36.9	39.3	5.35	30	172	173	106	40.7	43.1	5.05	27	181	177	100	44.6	47	4.76	24	188	181	93	48.8	51	4.46	21	195	184
140		147	38.6	43.6	7.01	37	128	155	139	42.4	47.4	6.66	33	140	161	132	46.5	52	6.3	30	152	167	124	51	56	5.94	27	163	172	117	56	61	5.57	24	173	177
160		159	47.6	53	7.62	34	112	152	151	53	58	7.21	31	128	159	142	58	63	6.79	28	142	165	134	63	68	6.38	25	155	171	125	69	74	5.96	22	167	176
200		200	55	63	9.57	20	206	203	190	61	68	9.06	18	210	207	179	67	75	8.55	16	214	211	169	74	81	8.06	14	217	215	159	81	88	7.57	13	220	218
240		235	67	77	11.3	27	192	189	223	74	84	10.7	24	198	194	210	81	91	10.1	22	203	200	198	89	99	9.45	19	207	204	185	98	108	8.85	17	212	209

Cooling capacities, single and dual pumps

30RH		Condenser entering air temperature, °C																																							
LWT	°C	25								30								35								40								45							
		CAP	COMP	UNIT	COOL	COOL	PRES	PRES		CAP	COMP	UNIT	COOL	COOL	PRES	PRES		CAP	COMP	UNIT	COOL	COOL	PRES	PRES		CAP	COMP	UNIT	COOL	COOL	PRES	PRES		CAP	COMP	UNIT	COOL	COOL	PRES	PRES	
							(1)	(2)							(1)	(2)							(1)	(2)							(1)	(2)							(1)	(2)	
		kW	kW	kW	l/s	kPa	kPa	kPa	kW	kW	kW	l/s	kPa	kPa	kPa	kW	kW	kW	l/s	kPa	kPa	kPa	kW	kW	kW	l/s	kPa	kPa	kPa	kW	kW	kW	l/s	kPa	kPa	kPa					
040	8	44.3	11.1	12.3	2.12	37	131	181	41.9	12.2	13.4	2	33	136	185	39.6	13.4	14.6	1.89	29	140	189	37.3	14.8	16	1.78	26	144	192	35	16.2	17.4	1.67	23	148	195					
050		50	15	16.2	2.4	30	134	187	47.6	16.6	17.8	2.27	26	139	190	45	18.4	19.6	2.15	24	143	193	42.3	20.2	21.4	2.02	21	147	196	39.7	22.1	23.3	1.9	19	150	199					
060		62	16.9	18.1	2.97	29	125	183	59	18.7	19.9	2.81	26	131	187	56	20.6	21.8	2.66	23	136	191	52	22.5	23.7	2.5	20	141	194	49.2	24.6	25.8	2.35	18	145	197					
070		76	19.5	22	3.61	35	103	171	72	21.4	23.9	3.43	32	111	176	68	23.5	26	3.25	28	118	181	64	25.7	28.2	3.07	25	126	186	60	28.1	30.6	2.88	22	132	190					
080		82	24.4	26.9	3.92	32	140	170	78	26.8	29.3	3.71	29	149	176	73	29.5	32	3.5	26	158	181	69	32.4	34.9	3.29	23	166	186	64	35.4	37.9	3.08	20	173	191					
090		96	25.1	27.5	4.56	42	110	151	90	27.8	30.2	4.32	38	122	159	85	30.6	33	4.08	34	133	166	80	33.6	36	3.84	31	143	172	76	36.8	39.2	3.61	27	153	178					
100		106	28	30.4	5.09	39	92	144	101	30.9	33.3	4.82	35	106	152	95	34	36.4	4.55	32	119	160	90	37.3	39.7	4.29	29	131	168	84	40.8	43.2	4.02	25	143	174					
120		122	33.8	36.2	5.82	35	158	165	115	37.4	39.8	5.52	32	168	170	109	41.1	43.5	5.21	28	176	175	103	45.1	47.5	4.91	25	184	179	96	49.3	52	4.61	23	192	183					
140		151	39	44	7.23	39	120	151	144	42.9	47.9	6.87	35	133	158	136	47	52	6.5	32	145	163	128	51	56	6.13	29	157	169	120	56	61	5.75	26	168	174					
160		164	48.2	53	7.84	36	104	148	155	53	58	7.42	33	120	155	147	58	63	7	29	135	162	138	64	69	6.58	26	149	168	129	70	75	6.16	23	162	174					
200		207	56	64	9.88	21	204	201	196	62	69	9.35	19	208	205	185	68	75	8.84	17	212	209	174	75	82	8.33	15	215	213	164	82	89	7.83	14	218	216					
240		243	68	78	11.6	28	189	185	230	75	85	11	25	195	191	217	82	92	10.4	23	200	197	204	90	100	9.76	20	205	202	191	99	109	9.14	18	210	207					
040	10	47.1	11.4	12.6	2.25	42	125	176	44.6	12.5	13.7	2.13	37	131	181	42.1	13.7	14.9	2.01	33	136	185	39.7	15.1	16.3	1.9	30	140	189	37.3	16.5	17.7	1.78	26	144	192					
050		53	15.4	16.6	2.54	33	129	183	50	17	18.2	2.41	30	134	186	47.8	18.7	19.9	2.28	27	138	190	45.1	20.6	21.8	2.15	24	143	193	42.4	22.5	23.7	2.02	21	147	196					
060		66	17.3	18.5	3.15	32	117	179	62	19.1	20.3	2.98	29	124	183	59	21	22.2	2.82	26	130	187	56	23	24.2	2.66	23	136	191	52	25.1	26.3	2.5	20	141	194					
070		80	20	22.5	3.83	39	92	164	76	21.9	24.4	3.65	36	101	170	72	24	26.5	3.45	32	110	176	68	26.2	28.7	3.26	28	118	181	64	28.6	31.1	3.06	25	126	186					
080		87	25	27.5	4.15	36	129	163	82	27.5	30	3.93	32	139	170	78	30.2	32.7	3.71	29	149	176	73	33.1	35.6	3.49	25	158	181												
090		101	25.8	28.2	4.84	47	95	142	96	28.4	30.8	4.59	43	108	150	91	31.3	33.7	4.34	38	121	158	86	34.3	36.7	4.09	34	132	165	81	37.5	39.9	3.85	31	143	172					
100		113	28.7	31.1	5.4	44	75	133	107	31.6	34	5.12	40	91	143	101	34.7	37.1	4.84	36	105	152	95	38.1	40.5	4.56	32	119	160	90	41.6	44	4.28	28	132	168					
120		129	34.6	37	6.17	39	147	160	122	38.2	40.6	5.85	35	157	165	116	42	44.4	5.53	32	167	170	109	46	48.4	5.22	28	176	175	103	50	53	4.9	25	184	179					
140		161	39.9	44.9	7.67	43	102	143	153	43.8	48.8	7.29	39	117	150	145	48	53	6.91	36	131	157	136	52	57	6.52	32	145	163	128	57	62	6.12	29	157	169					
160		174	49.4	54	8.3	40	85	139	165	54	59	7.86	36	103	148	155	60	65	7.42	33	120	155	146	66	71	6.98	29	135	162												
200		220	58	65	10.5	23	199	196	208	63	71	9.94	21	203	200	197	70	77	9.4	19	208	205	186	76	84	8.87	17	212	209	175	84	91	8.35	15	215	213					
240		257	69	79	12.3	31	182	178	244	76	86	11.7	28	188	185	230	84	94	11	25	194	191	217	92	102	10.4	23	200	197	203	101	111	9.71	20	205	202					

Legend:
LWT Leaving water temperature
CAP kW Net cooling capacity
COMP kW Compressor power input
UNIT kW Unit power input, (compressors, fans and control circuit)
COOL l/s Evaporator water flow rate
COOL kPa Evaporator pressure drop
PRES kPa (1) Available pressure at the unit outlet (unit with single-pump hydronic module)
PRES kPa (2) Available pressure at the unit outlet (unit with dual-pump hydronic module)

Application data:
Standard units
Refrigerant: R-407C
Evaporator temperature rise: 5 K
Evaporator fluid: water
Fouling factor: 0.44 x 10⁻⁴ (m² K)/W
Performances in accordance with EN 14511.

Guide specifications

Aquasnap 30RH

Nominal cooling capacity 38-210 kW

Nominal heating capacity 38-229 kW

Reversible air-to-water heat pumps for outdoor installation, equipped with scroll compressors, low-noise fans, auto-adaptive microprocessor control and operating with HFC-407C refrigerant which has no effect on the ozone layer.

Part 1 - General

Quality assurance

- 30RH units comply with requirements of European directives:
 - machinery directive 98/37/EC, modified,
 - low voltage directive 73/23/EEC, modified.
 - electromagnetic compatibility directive 89/336/EEC, modifiedand with the applicable recommendations of European standards:
 - machine safety, electrical equipment in machines, general regulations: EN 60204-1,
 - radiated electromagnetic emissions: EN 50081-1,
 - conducted electromagnetic emissions: EN 50081-2,
 - electromagnetic immunity EN 50082-2.

30RH units have been designed and tested in a facility with a quality assurance system certified ISO 9001.

30RH units have been assembled in a facility with an environment management system certified ISO 14001.

The published performances have been certified by Eurovent and verified by independent laboratories. All units undergo a run test before shipment.

Part 2 - Products

Equipment

Compressor

- Hermetic scroll compressor with only three moving parts, 2-pole electric motor, cooled by suction gas with overload protection through an internal thermostat and/or thermal relay. Oil level sight glass and polyolester synthetic oil charge.

Water heat exchanger

- Stainless steel plate heat exchanger with welded copper connections; from size 30RH 090 upwards the water heat exchanger has two interlaced independent refrigerant circuits.
- Closed-cell thermal foam insulation. Anti-freeze protection during operation by flow switch (standard on all versions) and during shutdown down to -20°C by electric resistance heater.

Air heat exchanger/fan

- One (30RH 040-080) or two (30RH 090-240) vertical coils with slotted aluminium fins expanded into grooved copper tubes. Coil protection grille made of steel wire, coated in polyethylene. Protection against ice build-up by electric resistance heater on the coil support.
- Low-noise axial Carrier Flying Bird fan with 11 blades and a rotating shroud, made of a composite material. Three-phase, two-speed motor (11.5/5.8 r/s or 15.6/7.8 r/s), insulation class F, protection category IP 55, overload protection by thermal relay. Vertical air flow with protection grille made of steel wire, coated in polyethylene.

Refrigerant circuit

- Each circuit includes: a four-way cycle reversing valve, liquid line valve, moisture sight glass, two-way expansion device, receiver/heat exchanger, protecting the compressor against refrigerant migration, removable suction line screen filter, high-pressure safety valve, pressure and temperature sensors, manually reset high pressure switch, and a refrigerant charge of HFC-407C. All components of the refrigerant circuit are welded for total and lasting leak-tightness.

Control and power circuit control box

- The control box is accessible via a hinged door. It includes a main disconnect switch, fuses and circuit breakers, compressor, fan and water pump contactors, thermal relays, low-voltage control circuit transformer (24 V control circuit) and the Pro-Dialog control system.

The whole unit is supplied by a single power connection point (three-phase supply without neutral).

Chassis/cabinet

- Chassis and cabinet made of galvanised sheet steel. Painted in oven-baked polyester powder paint in light grey colour (RAL 7035). Removable panels with 1/4 turn locks.

Hydronic module

- Hydronic module, integrated into the heat pump, including: removable screen filter, expansion tank, single monocell centrifugal water pump (dual water pump optional) - three-phase motor with internal thermal protection, water flow switch, safety valve (set to 3 bar for 30RH 040-160 and to 4 bar for 30RH 200-240 units), flow control valve, pressure gauge and purges. Internal piping made of galvanised steel. Customer-side Victaulic connections with welding or screw connection sleeves. Protection against ice build-up down to -20°C by thermal insulation and water pump cycling.

Note: Units without hydronic module (option): internal water piping protected against frost down to -10°C by electric resistance heater.

Carrier Pro-Dialog Plus control system

Pro-Dialog Plus ensures the following functions:

Control

- Entering or leaving water temperature control by PID loop with compressor run time equalising. The system permanently adjusts the system inertia and ensures complete prevention of excessive compressor cycling. The heat pump can safely operate with a low system water volume which often makes the use of a buffer tank unnecessary (see minimum water volume in this document).
- Head pressure control by auto-adaptive algorithm (fan speed).
- Water pump control (optional dual pump with automatic change-over).
- Defrost cycle control with auto-adaptation of the parameters.
- Control at the second set point (example: unoccupied room).
Set point reset as a function of the air temperature or the difference between entering/leaving water temperature.
- Automatic change-over of heating/cooling, as a function of the outdoor temperature with adjustable dead band.
Optional control module with a relay for the control of supplementary electric resistance heaters. Four stages maximum, with start-up of the last stage in case of a heat pump shutdown as a result of a fault condition.

Safety

- The system checks the evolution of the parameters: temperatures, pressures ... and responds to maintain the compressor within the operating range. If despite this one parameter exceeds its limit, an alert message is generated or the unit is shut down. The following faults cause the refrigerant circuit or the unit to be shut down:
 - Low suction pressure
 - High discharge pressure
 - Low suction temperature
 - Low water entering temperature in heating mode
 - Compressor, water pump overload
 - Reverse compressor rotation
 - Temperature sensor and pressure transducer fault
 - Board and loss of communication fault
 - Customer safety device tripping
 - Heat exchanger anti-freeze protection
 - More than 50 alert or fault codes to facilitate fault detection

Operator interface

- Includes status or fault LEDs, two numerical displays, a refrigerant system synoptic diagram and a command keyboard.
- Immediate display of parameters: entering/leaving water and ambient air temperatures, compressor suction/discharge pressures and temperatures, set point, operating temperatures and number of compressor start-ups.
- Diagnosis and complete parameter set by selection of one of the following menus: information, temperatures, pressures, set points, input values, test, configuration, alarms, alarm history and operating log.

Remote management of the heat pump

- Volt-free contact inputs permit:
 - Start/stop control
 - Selection of cooling or heating mode
 - Integration of a customer safety device
 - Operation at the second set point* (example room unoccupied)
 - Maximum demand limit* (three limit levels from size 30RH 090 upwards)

* One or the other for 30RH 040-080
- Outputs are available for:
 - Start-up of a boiler relay (shutdown of the heat pump below a minimum outdoor temperature)
 - Signalling of a fault condition for each circuit.
- The internal clock permits programming of the following operations:
 - heat pump start/stop
 - control at the second set point (e.g. unoccupied room)
 - fan at low speed to reduce the noise level (e.g. during the night)
- Master/slave control of two heat pumps operating in parallel with operating time equalisation.
- RS 485 serial port for remote heat pump control via communications bus.